

8 & 10 TA

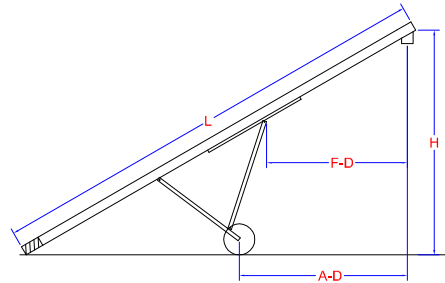

L	30°			35°			MAX ANGLE		
	H	A-D	F-D	H	A-D	F-D	DEG.	H	A-D
31'	15' 8"	11' 9"	9' 10"	--	--	--	43°	21' 5"	11' 3"
41'	20' 8"	15' 10"	13' 4"	--	--	--	43°	28' 5"	13' 8"
51'	25' 8"	20' 4"	16' 7"	29' 5"	19' 3"	17' 8"	45°	36' 4"	16' 8"
56'	28' 2"	22' 2"	18' 5"	32' 4"	20' 11"	19' 9"	45°	40' 3"	17' 11"
61'	30' 8"	24' 6"	20' 8"	35' 2"	23' 3"	22' 2"	45°	43' 7"	20' 3"
66'	33' 2"	26' 6"	21' 9"	38' 1"	25' 3"	23' 5"	45°	47' 0"	22' 2"
71'	35' 8"	28' 8"	25' 1"	40' 11"	27' 5"	26' 10"	45°	50' 7"	24' 5"

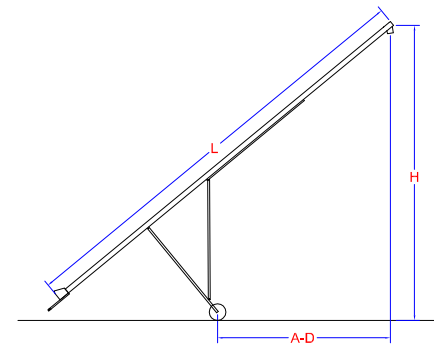

8 & 10 TAD

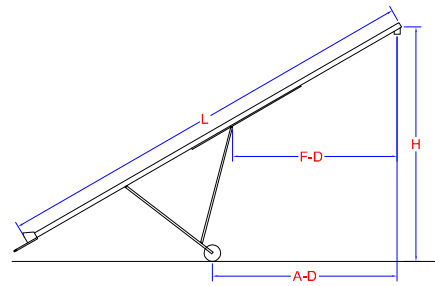

L	30°			35°			MAX ANGLE		
	H	A-D	F-D	H	A-D	F-D	DEG.	H	A-D
56'	30' 7"	24' 2"	21' 6"	34' 10"	23' 3"	22' 10"	40°	38' 6"	22' 6"
61'	33' 1"	26' 10"	23' 11"	37' 9"	25' 10"	25' 0"	41°	42' 11"	24' 7"
66'	35' 7"	29' 0"	25' 3"	40' 8"	27' 11"	26' 8"	41°	46' 3"	26' 7"
71'	38' 1"	31' 2"	28' 5"	43' 6"	30' 2"	30' 1"	41°	49' 10"	28' 10"
76'	40' 7"	35' 6"	32' 9"	46' 5"	34' 3"	--	41°	53' 1"	32' 7"

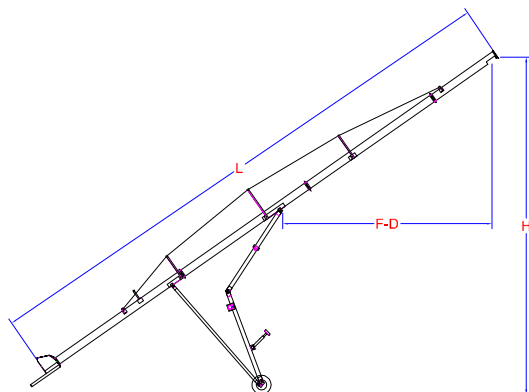

12TAD

L	30°		35°		MAX ANGLE		
	H	F-D	H	F-D	DEG.	H	F-D
72'	38' 1"	28' 6"	43' 7"	27' 0"	40°	48' 3"	25' 4"
82'	43' 4"	32' 8"	49' 3"	31' 0"	41°	56' 3"	28' 4"